

**ROTATION ON STABILISERS  
FULLY EXTENDED WITH FORKS**

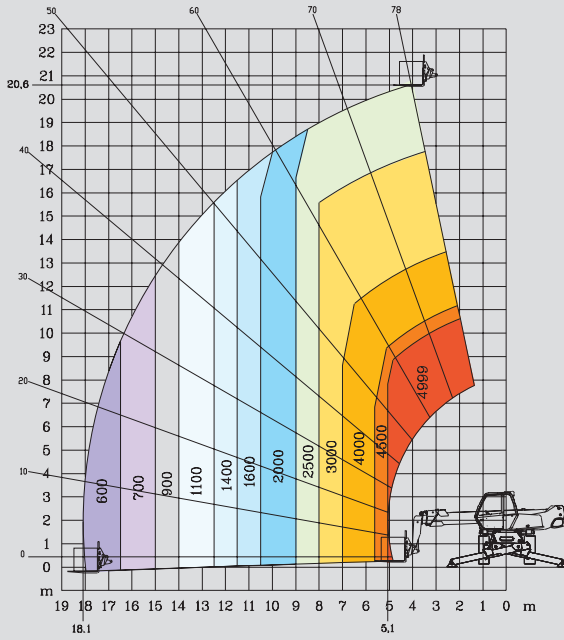

**FRONTAL POSITION ON WHEELS  
WITH FORKS**

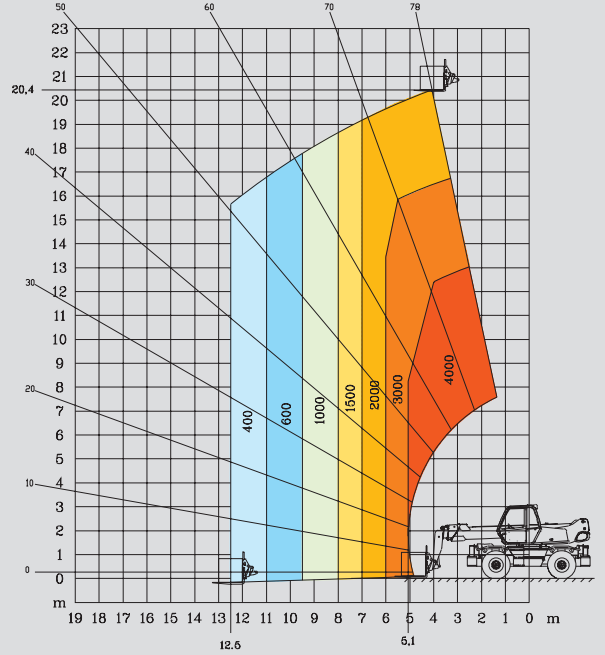

**ROTATION ON STABILISERS NOT FULLY EXTENDED  
WITH FORKS**

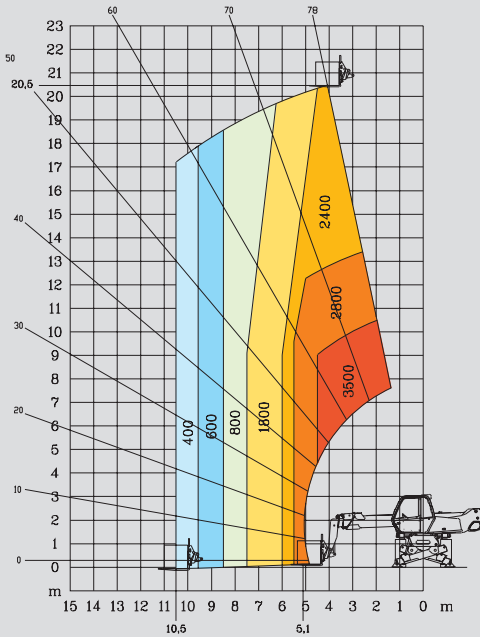

**ROTATION ON STABILISERS FULLY EXTENDED  
WITH 5T WINCH**

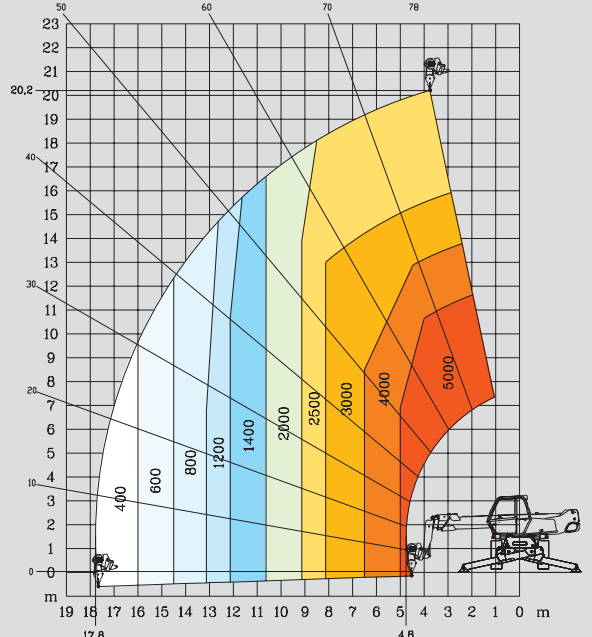

**ROTATION ON STABILISERS FULLY EXTENDED  
WITH JIB P 600**

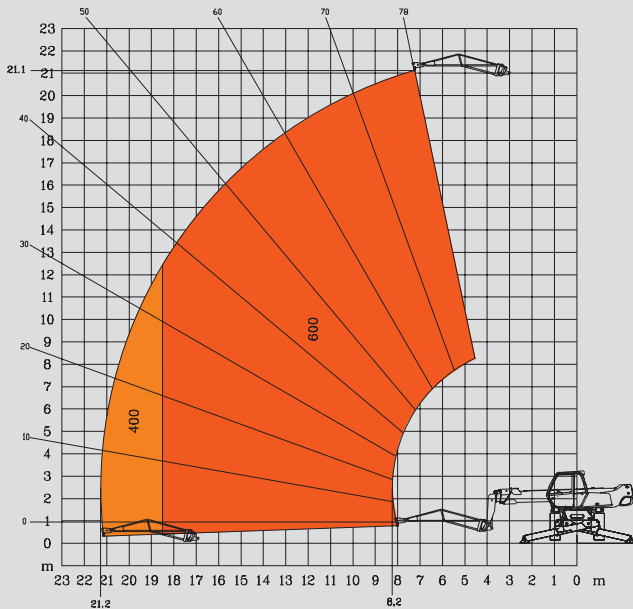

**ROTATION ON STABILISERS FULLY EXTENDED  
WITH JIB P 1500**

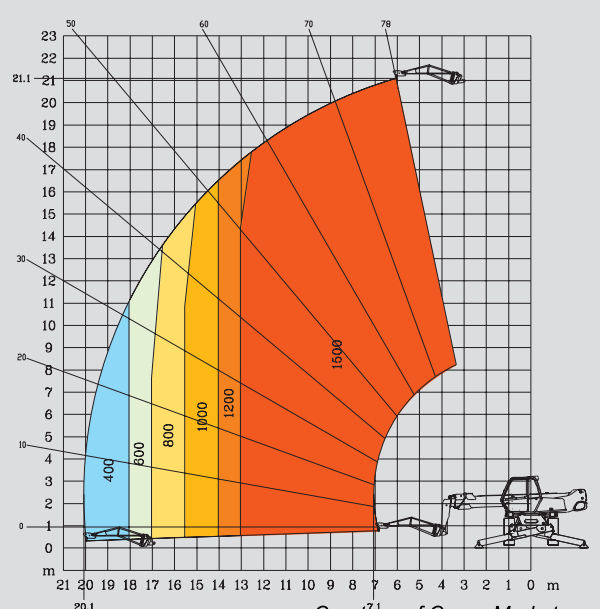

**ROTATION ON STABILISERS FULLY EXTENDED WITH EXTENSIBLE PLATFORM 2,25/4 m**

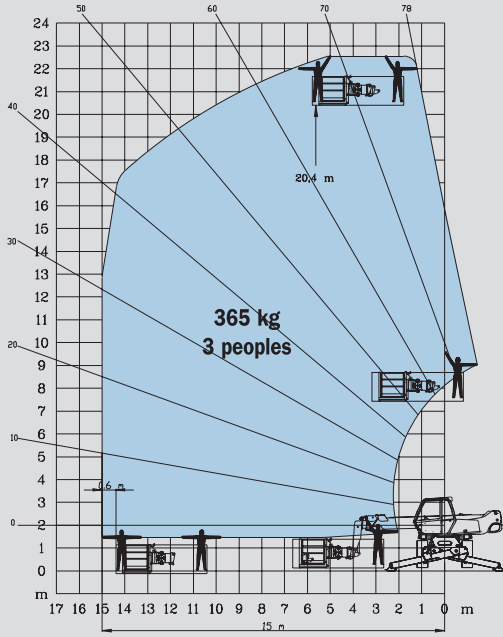

**ROTATION ON STABILISERS FULLY EXTENDED WITH 1000 KG PLATFORM 2,25/4 m**

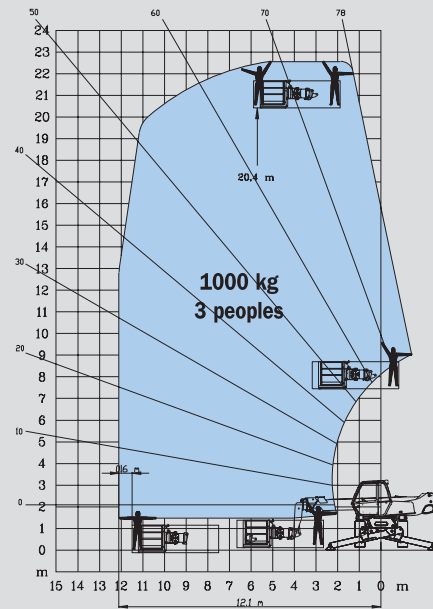

**ROTATION ON STABILISERS FULLY EXTENDED WITH 3 D SYSTEM IN POSITIVE POSITION**

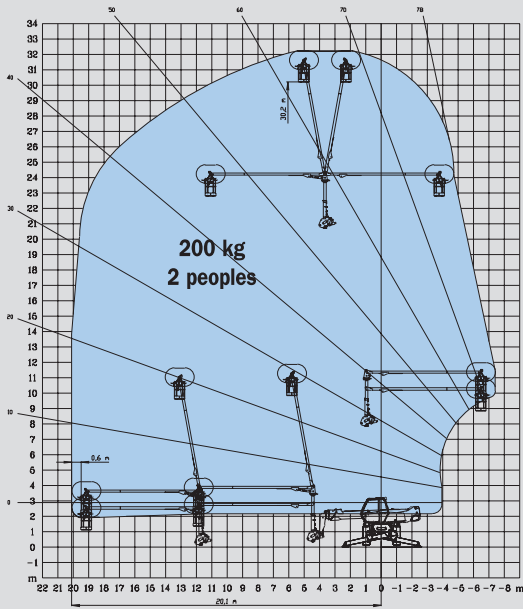

**ROTATION ON STABILISERS FULLY EXTENDED WITH 3 D SYSTEM IN NEGATIVE POSITION**

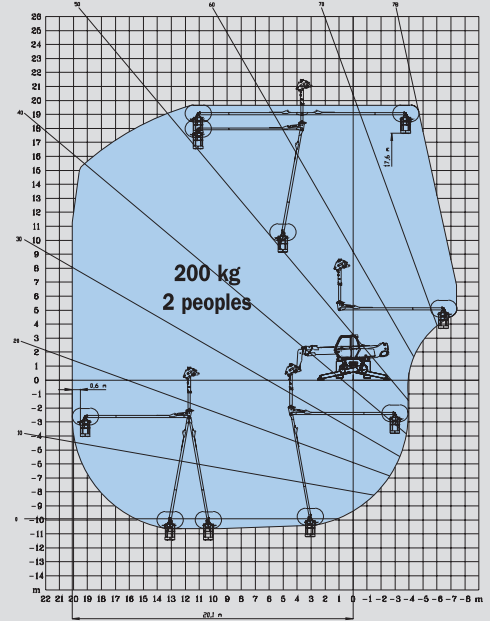

**ROTATION ON STABILISERS FULLY EXTENDED WITH AERIAL JIB PLATFORM**

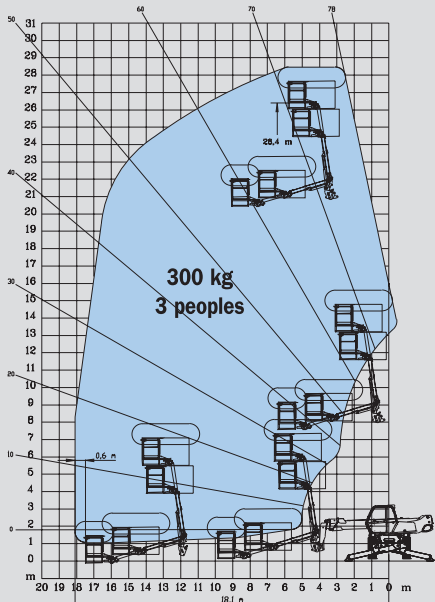

**ROTATION ON STABILISERS FULLY EXTENDED WITH CRANE JIB**

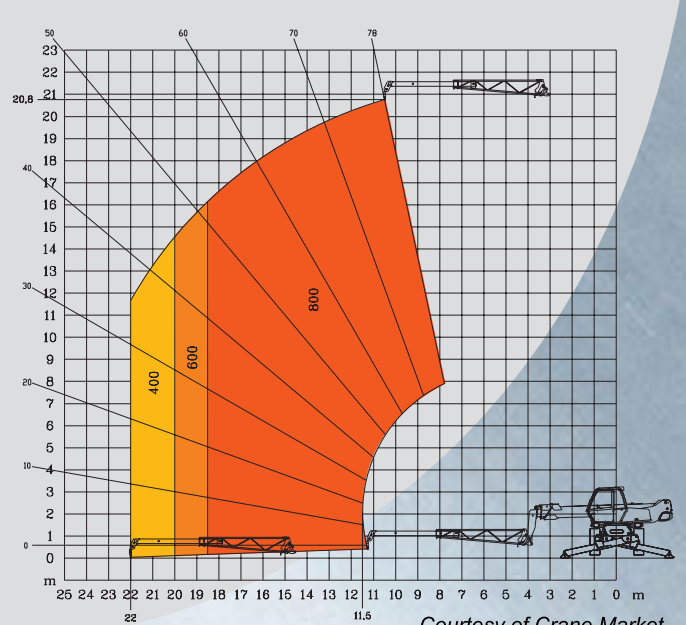

## MRT 2150 *M Series*



**Lift capacity** (on stabilisers) .....4999 kg  
at 500 mm from forks heels



**Lift height** : .....20.60 m



**Tyres**  
18 - 22,5



**Forks** (mm)  
Length .....1200  
Width x thickness .....150 X 50



**Multidisc brakes** : hydraulically assisted on both axles  
Negative parking brake



**Engine PERKINS**  
Type .....1104C - 44 TA  
Capacity .....4 cyl. 4400 cm<sup>3</sup>  
Power (ISO/TR 14396) .....132 HP/97 kw  
500 Nm at 1400 rpm  
Water cooling  
Direct injection



**Transmission** .....hydrostatic  
With automatic power regulation (hydraulic variable displacement pump and motor)  
Reversing shift .....electromagnetic  
2 speed forward and reverse  
Travel speed .....25 km/h



**Rear axle**  
**Frame levelling on front axle +/- 8° (15%)**  
Automatic rear axle locking system  
over 15° rotation



**4 stabilizers**  
simultaneous or individually controlled



**Total and continuous rotation**  
Turret mounted on a double slew ring  
Hydraulic and electric rotation



**Hydraulics**  
3 pumps gear type .....270 bars/160 l/mn



**Control** : 2 electro proportional control joysticks for all hydraulic movements



**Capacities**  
Cooling system .....15 l.  
Engine oil .....11.5 l.  
Hydraulic oil .....200 l.  
Fuel tank .....230 l.



**Weight unladen** (with forks) .....16095 kg  
**Overall width** .....2.43 m  
**Overall height** .....3.02 m  
**Overall length** .....6.78 m  
**Ground clearance** .....0.37 m  
**Drawbar pull** .....10800 daN



**Standard load moment indicator**  
(mobile crane standards)

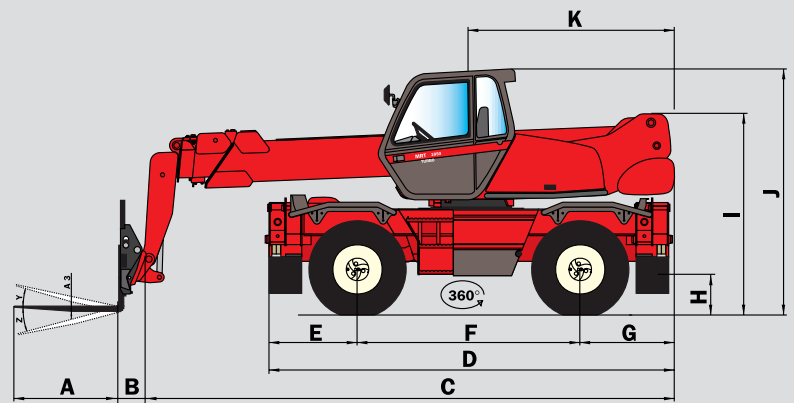

A	1200
A1	150
A2	1030
A3	60
B	290
C	6490
D	5050
E	1155
F	2750
G	1155
H	370
I	2420
J	3025
K	2485
L	1930
M	2425
N	4700
O	5100
P	200
Q	4500
R	3800
S	4550
V	950
Y	12°
Z	105°

mm

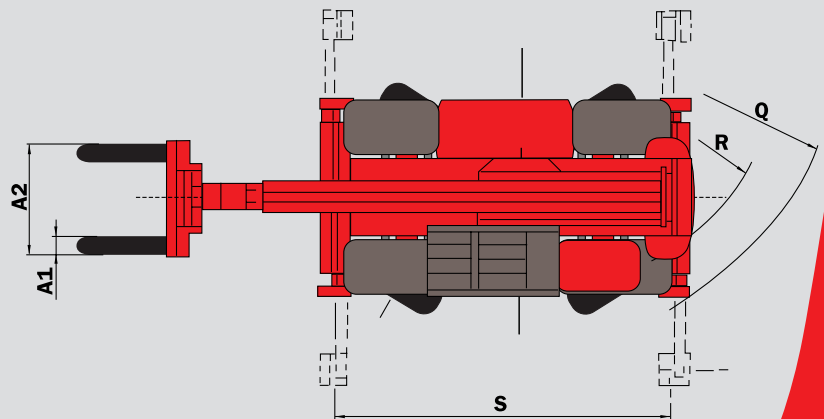
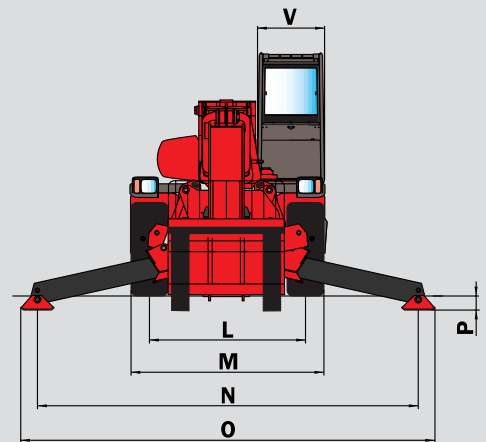

This publication in no way constitutes an offer and the company reserves the right to alter specification without prior notice.  
The MANITOU models presented in this brochure can be supplied complete with optional equipment attachments.



207/04/2003



**MANITOU B.F. S.A.**  
B.P.249 - 44158 ANCENIS CEDEX - FRANCE  
TEL : 33 2 40 09 10 11  
EXPORT DEPARTMENT FAX : 33 2 40 09 10 97  
www.manitou.com

Courtesy of Crane.Market